

m  
Materasso

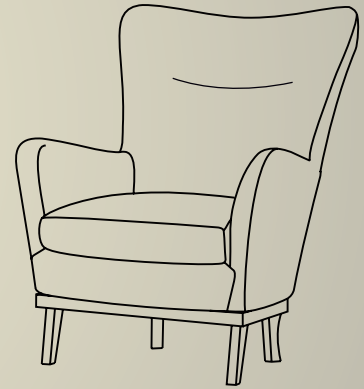
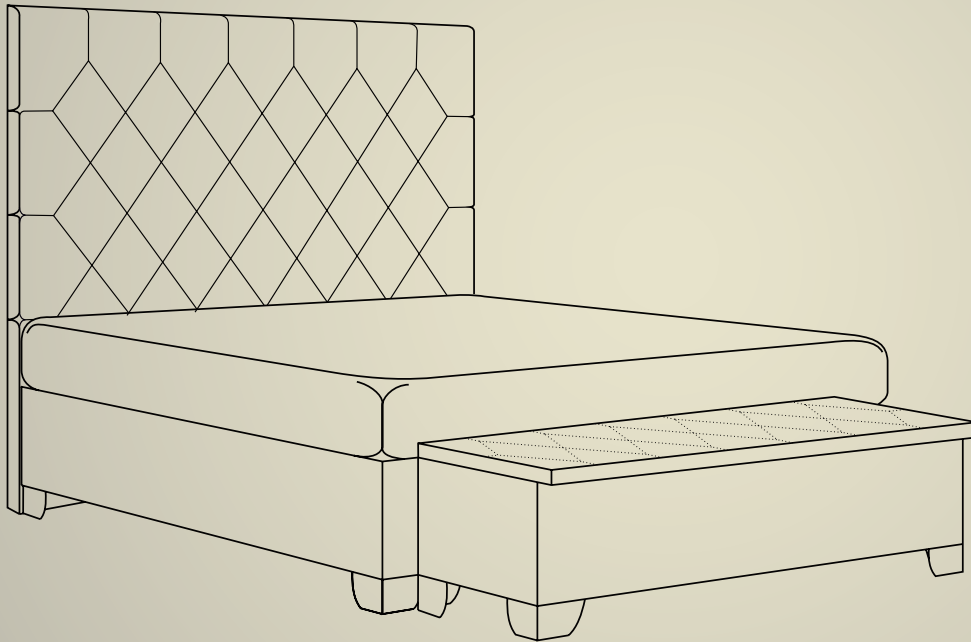

m  
Materasso

RHOMBUS	7
HORIZONTAL	9
WILD	11
INDUSTRY	13
KINGSTONE	15
NOBILIA	17
SPECTRA	19
NAVY	21
ENIF	23
GEMINI	25
FRANCESCA	26
CLAUDIA	28
SIRIUS	30
VELORUM	32
VEGA	35
ARGENTINA	37
BELLATRIX	39
ATLAS	41
SIENA	42
CORONA	44
ALESIA	46
MIRACH	48
PARIS	51
VIENNA	53
DE LUXE	54
BREEZE	55
MODERN	56
TABURET	57

# m Materasso

Pre tých, ktorí milujú spánok

Spálňa je najintímnejšia a najdôležitejšia miestnosť vo Vašom dome. Je to miesto, kde odpočívate a regenerujete svoje telo aj zmysly po celodennej námahe. Miesto, kde naberáte sily a pripravujete sa plniť nové výzvy. Uvedomujeme si, že posteľ je dominantou každej spálne a dáva jej dušu a charakter. Preto vám chceme predstaviť kolekciu našich čalúnených postelí, ktoré Vás budú hýčkať pri každom pohľade a poskytovať príjemný estetický zážitok. V spojení s ponukou našich zdravotných matracov Vám zabezpečia pohodlie a zdravý odpočinok na najvyššej úrovni.

Postele v tejto kolekcii predstavujú krásny dizajn, bohatý výber poťahových látok a farebných prevedení, pevnú konštrukciu, ale hlavne perfektné vypracovanie. Veľký dôraz kladieme na funkčnosť a možnosť vytvorenia modelov postelí presne podľa Vašich predstáv. Vďaka veľkému množstvu variácií v ponuke tvarov a dizajnov, tiež farieb a doplnkových funkcií, určite nájdete v našej ponuke posteľ, ktorou presne dotvoríte štýl Vášho interiéru tak, aby sa spálňa stala najútulnejším miestom vo Vašom dome.

Firma Materasso je tím nadšencov s obrovskými a dlhoročnými skúsenosťami v oblasti výroby ortopedických matracov a postelí. Stavíme predovšetkým na kvalite vypracovania a použitých materiálov. Dôležitú úlohu hrá aj dôsledné zladenie jednotlivých elementov. Naši dizajnéri a konštruktéri sa snažia využívať všetky informácie v oblasti nových trendov, ale tiež vychádzajú v ústrety predstavám a očakávaniam našich zákazníkov. Preto je pre nás tak dôležitý Váš názor, Vaše túžby a individuálne predstavy ako by mala posteľ vyzerať. Na základe takýchto podnetov a požiadaviek sme vytvorili široký výber čiel postelí, v rôznych tvaroch a spôsoboch spracovania, rôznych druhov korpusov postelí s užšími, alebo hrubšími bočnicami. Taktiež je tu možnosť vyhotovenia postelí v atypickej dĺžke, v pohodlných boxspringových verziách známych hlavne z hotelov, vo verzii s úložným priestorom, ale tiež možnosť použitia rôznych druhov roštov od jednoduchých modelov, až k modelom s plným polohovaním pomocou elektromotorov cez ovládač.

Krásna a štýl ukrytý vo vysokej kvalite čalúnnických poťahovín, v ktorých nájdete nielen originálne vzory, štruktúry, ale tiež poťahové látky s úpravou pre ľahké čistenie, alebo látky hydrofóbne, odolávajúce absorpcii tekutín aj nečistôt. Každá posteľ z ponuky, bez rozdielu typu korpusu, je dostupná s pevnými nohami z rôznych druhov materiálov. Je možné vybrať z prírodných materiálov ako drevo, kov ale tiež aj z jednoduchších plastových druhov. Ďalšie možnosti ponúkajú rôzne tvary a výšky nožičiek.



individuálnej stavby tela a potrieb užívateľa a doplnkový matrac nazývaný toper. Takéto zloženie a skladba vytvára výnimočný systém podvojného kopírovania prirodzeného tvaru tela pre dosiahnutie komfortu, nedostupného pri iných spacích systémoch. Dizajn boxspringu môže dotvárať suknička (Cover), tak ako je to vyobrazené pri posteli PARIS.

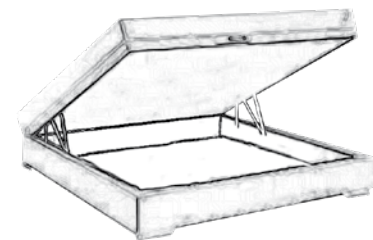

Riešenie úložného priestoru, bez ďalších vnútorných predelení, poskytuje výnimočne veľký odkladací priestor a výborný prístup do úložného priestoru po celej ploche.

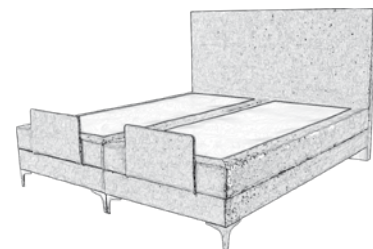

**Kontinentálne postele** sú najpokročivejším spacím systémom. Ich tajomstvo tkvie v špecifickej konštrukcii, ktorú tvoria dva, niekedy až tri komponenty: boxspring – s jadrom pružinovej konštrukcie, zabezpečujúci bodovo prispôsobivý podklad pod matracom; matrac-zvolený podľa

**Boxspring výklap MAXI** je ideálnym riešením pre všetkých, ktorí hľadajú komfortnú posteľ s prednosťami boxspringu, doplnenú o veľký úložný priestor vo vnútri postele. Konštrukcia boxspringového typu znižuje požiadavku na zaberajúci priestor v spálni a umožňuje použiť väčší rozmer matraca ako pri tradičnej posteli.

**Boxspring Mobil** je to korpus postele kontinentálneho typu, obohatený o funkciu plynulého polohovania hlavy a chrbtovej časti, alebo nôh pomocou elektromotorov s ovládačom. Posteľ tohto typu nemá vystupujúce bočnice a regulácia umožňuje nastavenie najlepšej pozície

pre odpočinok vzhľadom na momentálny stav a potreby. Iná je poloha pre spanie, iná pre aktívny odpočinok v posteli (napr. čítanie), iná pri opuchnutých nohách. Boxspring mobil dokonale spolupracuje s matracmi zo studených pien, s anatomicky prerezanými jadrami, latexovými a matracmi z lenivých -termo-elastických pien, presne kopírujúcich tvar roštu pri polohovaní.

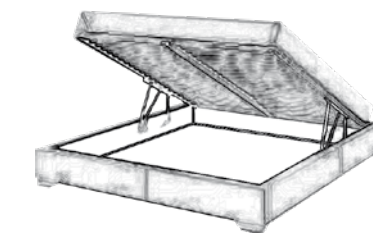

**Posteľ s úložným priestorom Metal** je pevné, tradičné riešenie postele určené pre tých, ktorí potrebujú množstvo úložného priestoru v spálni a tiež uprednostňujú jeden spoločný partnerský matrac. Tradičný rám postele možno vybrať v šírke 5 alebo 8 cm a výške 30 alebo 35 cm. Vybavený je špeciálnym roštom s kovovou konštrukciou, ktorý sa vyklápa z prednej

časti postele pomocou špeciálnych kovaní. Kovania s pneumatickými piestami uľahčujú prístup do úložného priestoru aj pri použití hrubých a ťažkých matracov. Rám roštu je sám o sebe pevný, odolný kovový prvok, v ktorom sú vložené pružné lamely spolupracujúce s každým typom matraca. Premyslená konštrukcia postele umožňuje prístup do celého úložného priestoru. Ľahká demontáž dna v úložnom priestore uľahčuje prístup pod celú plochu postele.

**Design Bed-Základná konštrukcia čalúnenej postele**, ktorá samozrejme môže byť spojená s akýmkoľvek dizajnom čela z našej ponuky, umožňuje použiť všetky naše rošty pod matrac: od jednoduchých latových masívnych, cez latové masívne v ráme, pružné lamelové,

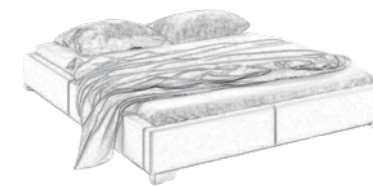

polohovateľné, až po modely s plynulým elektrickým polohovaním. Pre Vaše pohodlie sú korpusy vyrábané v dvoch rôznych šírkach: 5 alebo 8 cm a troch štandardných výškach: 15, 30 alebo 35 cm.



# RHOMBUS

NEW

	L	b <sup>L</sup>	b <sup>W</sup>	b <sup>H</sup>	h <sup>W</sup>	h <sup>H</sup>	m <sup>L</sup>	m <sup>W</sup> (cm)
<b>Boxspring 32</b>	208	200	180	32	180	160	200	180
	208	200	160	32	160	160	200	160

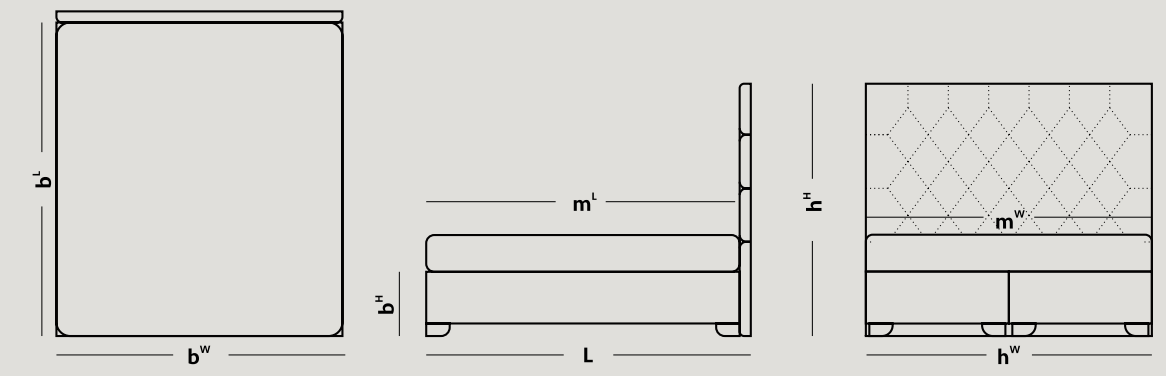



# HORIZONTAL

NEW

	L	b <sup>L</sup>	b <sup>W</sup>	b <sup>H</sup>	h <sup>W</sup>	h <sup>H</sup>	m <sup>L</sup>	m <sup>W</sup> (cm)
<b>Boxspring 32</b>	210	200	180	32	240	145	200	180
<b>MAXI</b>	210	200	160	32	<del>240</del> 220	145	200	160

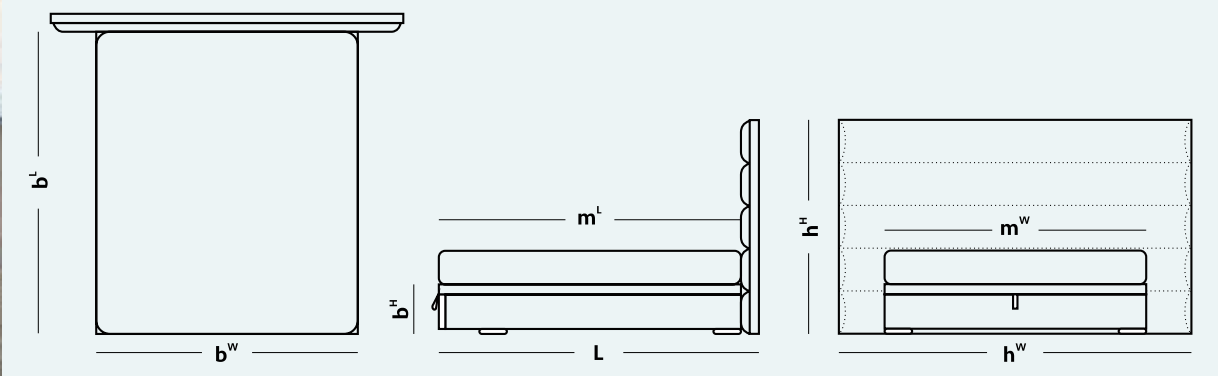



# WILD

NEW

	L	b <sup>L</sup>	b <sup>W</sup>	b <sup>H</sup>	h <sup>W</sup>	h <sup>H</sup>	m <sup>L</sup>	m <sup>W</sup> (cm)
<b>Boxspring 32</b>	208	200	180	32	180	160	200	180
	208	200	160	32	160	160	200	160

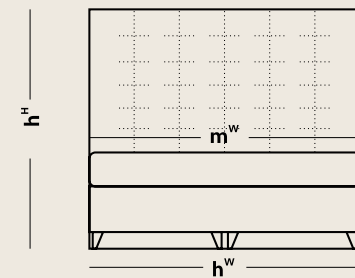
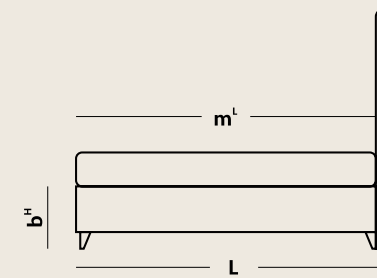
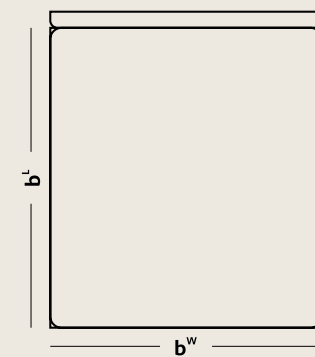



# INDUSTRY

NEW

	L	b <sup>L</sup>	b <sup>W</sup>	b <sup>H</sup>	p <sup>H</sup>	b <sup>D</sup>	h <sup>W</sup>	h <sup>H</sup>	m <sup>L</sup>	m <sup>W</sup>	(cm)
<b>Design-Bed</b>	225	205	190	20	13	5	190	103	200	180	
<b>Industry Design Bed</b>	225	205	170	20	13	5	170	103	200	160	

Industry Design Bed

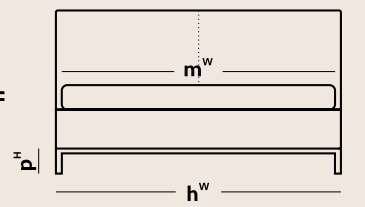
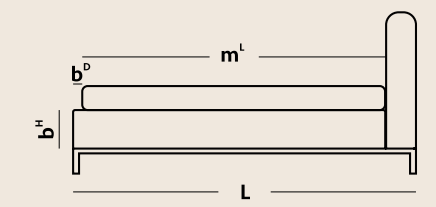
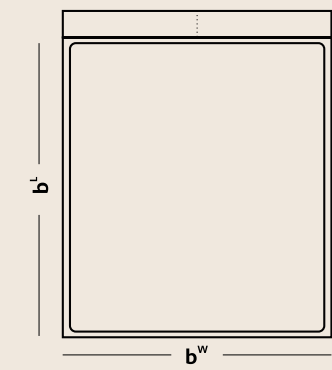



# KINGSTONE

NEW

	<b>L</b>	<b>b<sup>L</sup></b>	<b>b<sup>W</sup></b>	<b>b<sup>H</sup></b>	<b>b<sup>D</sup></b>	<b>h<sup>W</sup></b>	<b>h<sup>H</sup></b>	<b>m<sup>L</sup></b>	<b>m<sup>W</sup></b> (cm)
<b>Design Bed</b>	218	205	190	35	5	190	120	200	180
	218	205	170	35	5	170	120	200	160

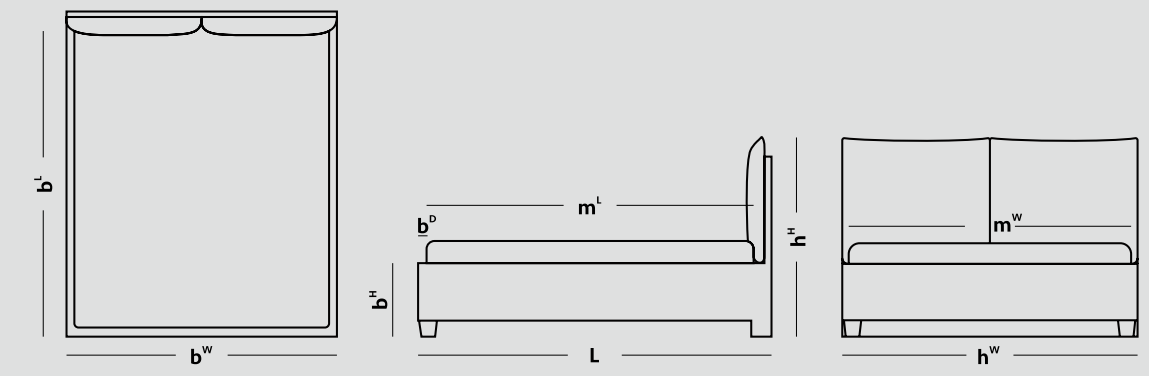





# NOBILIA

NEW

	L	b <sup>L</sup>	b <sup>W</sup>	b <sup>H</sup>	b <sup>D</sup>	h <sup>W</sup>	h <sup>H</sup>	m <sup>L</sup>	m <sup>W</sup> (cm)
<b>Design Bed</b>	213	205	190	30	5	190	120	200	180
	213	205	170	30	5	170	120	200	160

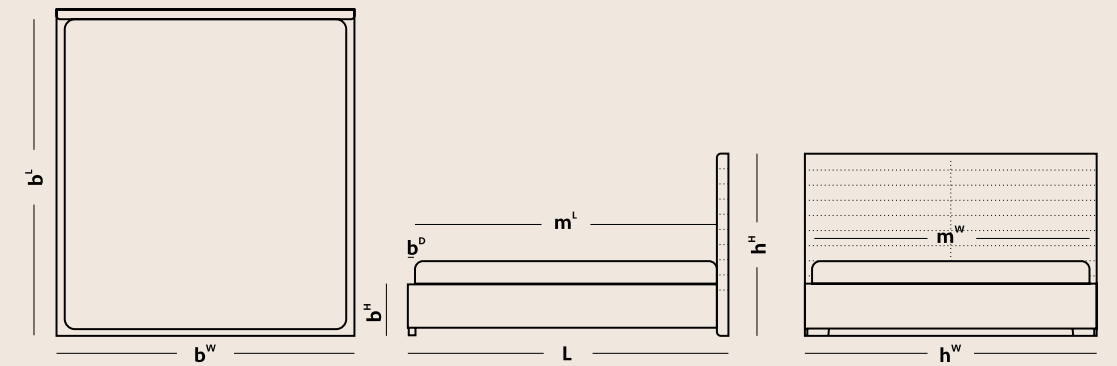



# SPECTRA

NEW

	L	b <sup>L</sup>	b <sup>W</sup>	b <sup>H</sup>	h <sup>W</sup>	h <sup>H</sup>	m <sup>L</sup>	m <sup>W</sup> (cm)
MAXI	208	200	180	32	180	130	200	180
	208	200	160	32	<del>180</del> 160	130	200	160

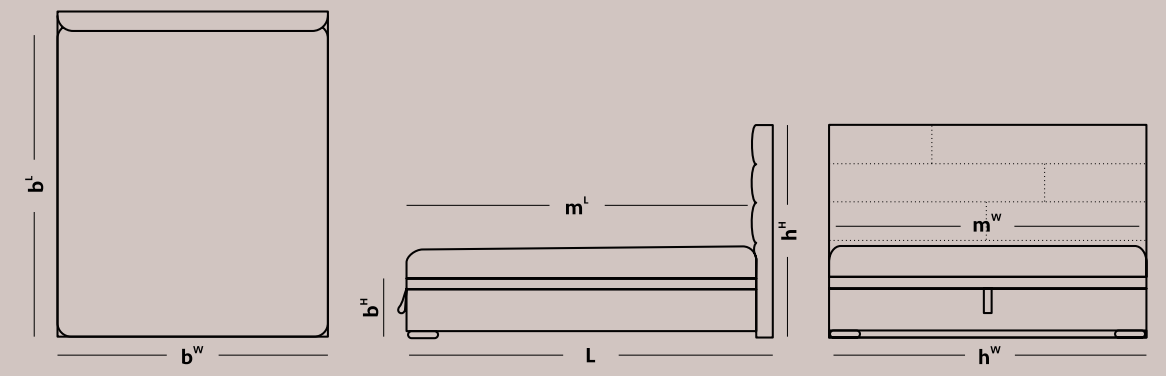



# NAVY

	<b>L</b>	<b>b<sup>L</sup></b>	<b>b<sup>W</sup></b>	<b>b<sup>H</sup></b>	<b>b<sup>D</sup></b>	<b>h<sup>W</sup></b>	<b>h<sup>H</sup></b>	<b>m<sup>L</sup></b>	<b>m<sup>W</sup></b> (cm)
<b>Design Bed</b>	213	205	190	30	5	190	123	200	180
	213	205	170	30	5	170	123	200	160

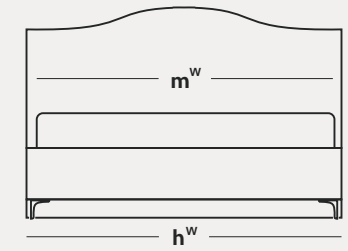
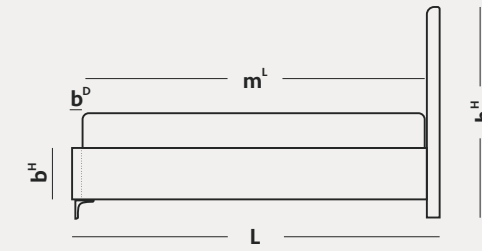
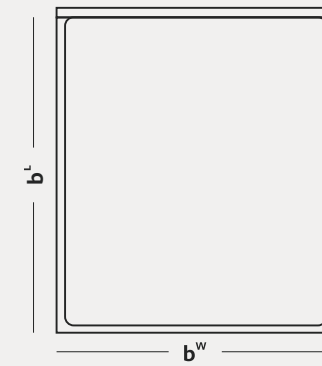



# ENIF

	L	b <sup>L</sup>	b <sup>W</sup>	b <sup>H</sup>	b <sup>D</sup>	h <sup>W</sup>	h <sup>H</sup>	m <sup>L</sup>	m <sup>W</sup> (cm)
<b>Design Bed</b>	213	205	190	35	5	196	123	200	180
	213	205	170	35	5	176	123	200	160

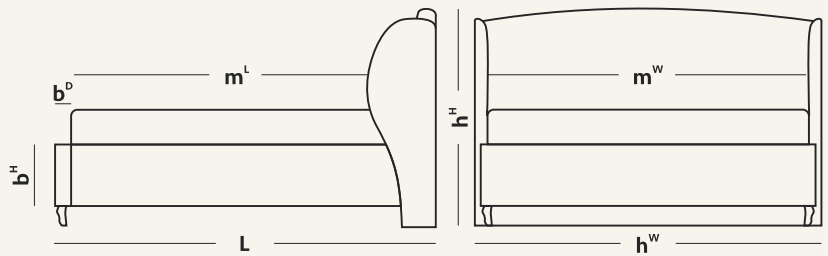
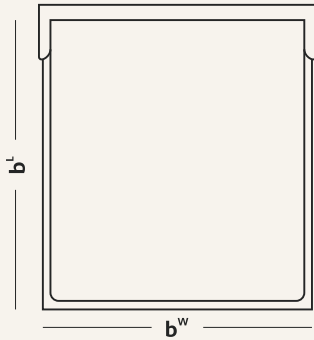



# GEMINI

	L	b <sup>L</sup>	b <sup>W</sup>	b <sup>H</sup>	b <sup>D</sup>	h <sup>W</sup>	h <sup>H</sup>	m <sup>L</sup>	m <sup>W</sup> (cm)
<b>Design Bed</b>	213	205	190	30	5	190	150	200	180
	213	205	170	30	5	170	150	200	160

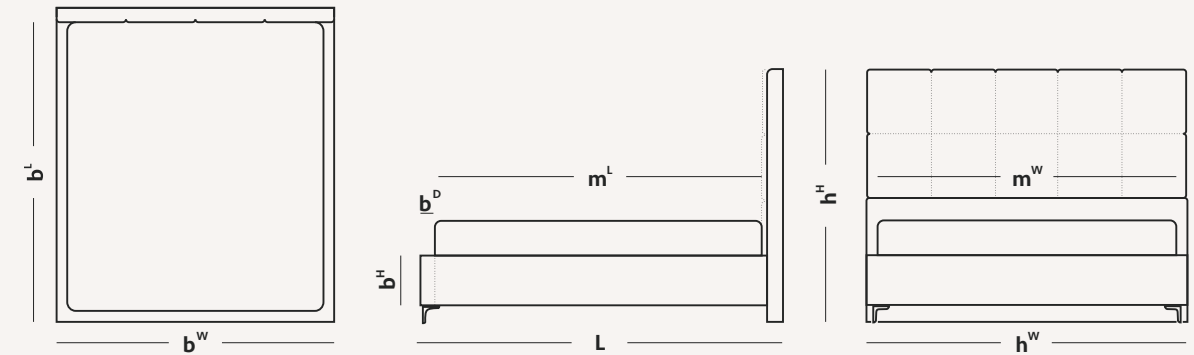

# FRANCESCA

	L	b <sup>L</sup>	b <sup>W</sup>	b <sup>H</sup>	b <sup>D</sup>	h <sup>W</sup>	h <sup>H</sup>	m <sup>L</sup>	m <sup>W</sup> (cm)
<b>Design Bed LUX</b>	240	205	190	30	5	190	103	200	180
	240	205	170	30	5	170	103	200	160

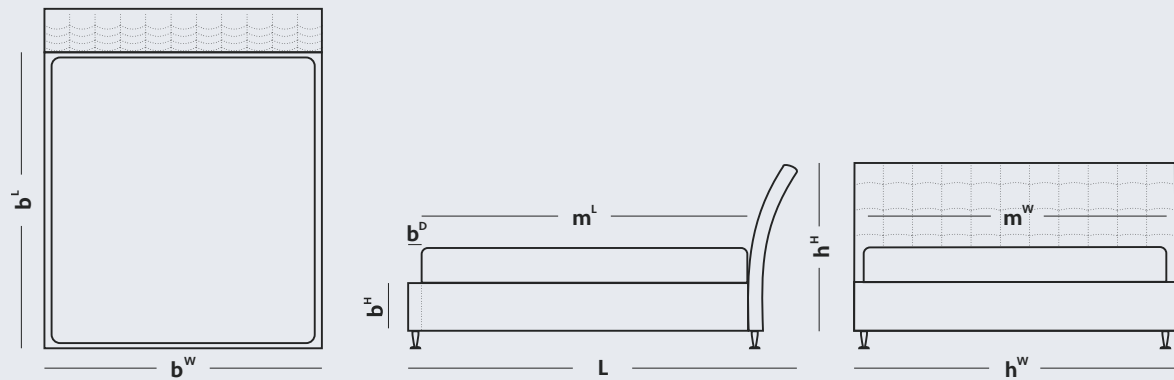

# CLAUDIA

	L	b <sup>L</sup>	b <sup>W</sup>	b <sup>H</sup>	b <sup>D</sup>	h <sup>W</sup>	h <sup>H</sup>	m <sup>L</sup>	m <sup>W</sup> (cm)
<b>Design Bed LUX</b>	243	208	196	30	8	196	103	200	180
	243	208	176	30	8	176	103	200	160

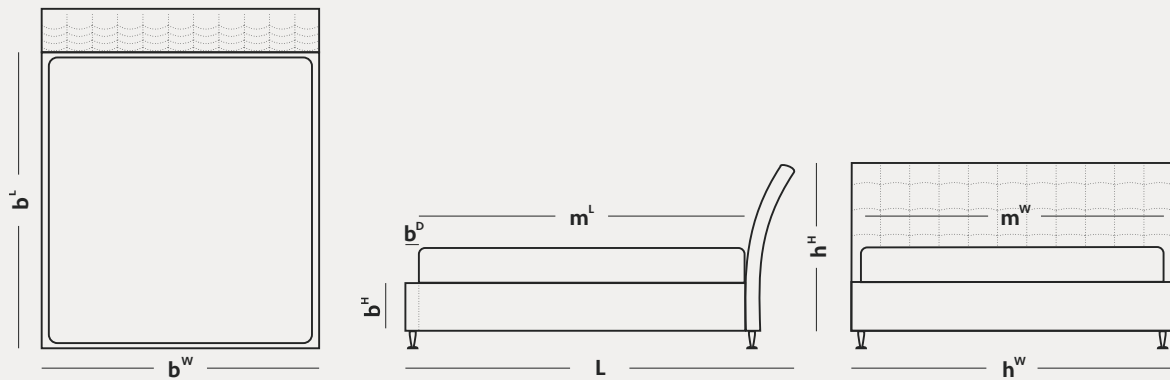

# SIRIUS

	L	b <sup>L</sup>	b <sup>W</sup>	b <sup>H</sup>	h <sup>W</sup>	h <sup>H</sup>	m <sup>L</sup>	m <sup>W</sup> (cm)
Boxspring mobil	208	200	180	32	180	120	200	180
	208	200	160	32	160	120	200	160

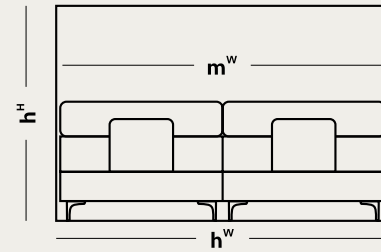
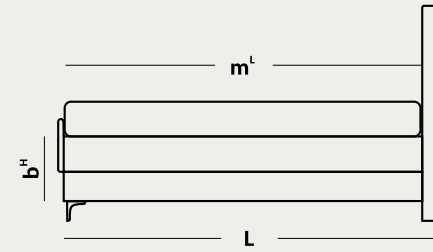
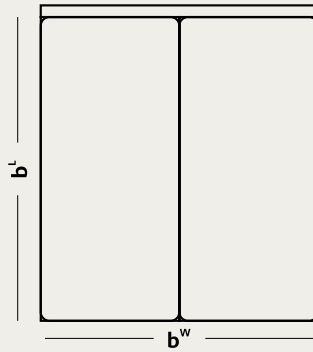



# VELORUM

	L	b <sup>L</sup>	b <sup>W</sup>	b <sup>H</sup>	h <sup>W</sup>	h <sup>H</sup>	m <sup>L</sup>	m <sup>W</sup> (cm)
<b>Boxspring 32</b>	208	200	180	32	180	120	200	180
	208	200	160	32	160	120	200	160

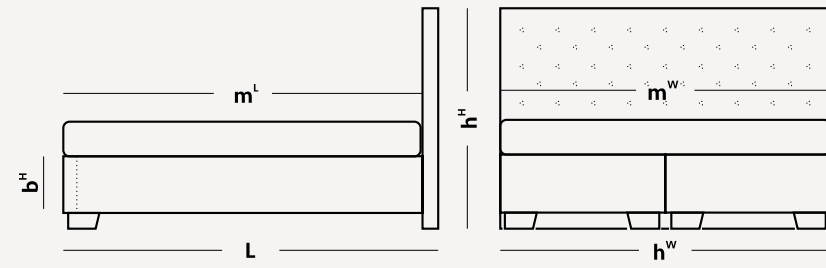
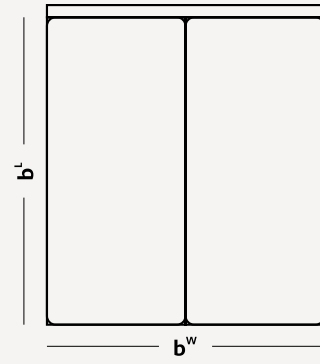



# VEGA

	<b>L</b>	<b>b<sup>L</sup></b>	<b>b<sup>W</sup></b>	<b>b<sup>H</sup></b>	<b>b<sup>D</sup></b>	<b>h<sup>W</sup></b>	<b>h<sup>H</sup></b>	<b>m<sup>L</sup></b>	<b>m<sup>W</sup></b> (cm)
<b>Design Bed</b>	213	205	190	30	5	190	130	200	180
	213	205	170	30	5	170	130	200	160

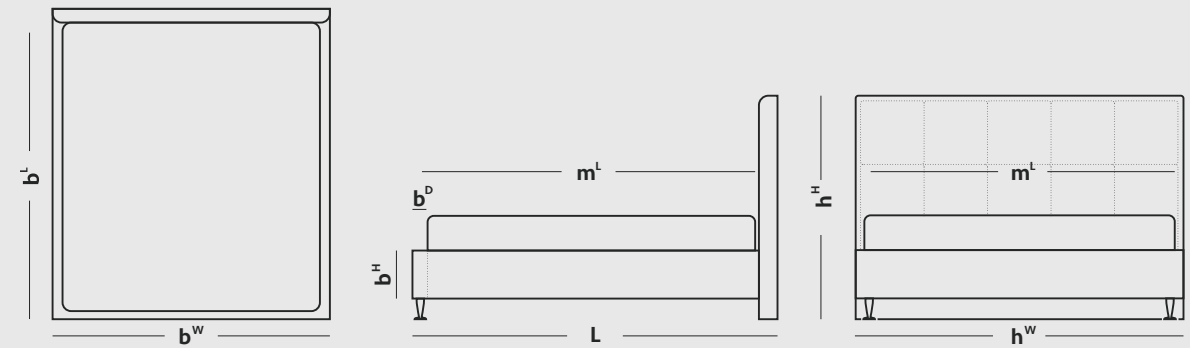



# ARGENTINA

	<b>L</b>	<b>b<sup>L</sup></b>	<b>b<sup>W</sup></b>	<b>b<sup>H</sup></b>	<b>b<sup>D</sup></b>	<b>h<sup>W</sup></b>	<b>h<sup>H</sup></b>	<b>m<sup>L</sup></b>	<b>m<sup>W</sup></b> (cm)
<b>Design Bed</b>	213	205	190	35	5	190	120	200	180
	213	205	170	35	5	170	120	200	160

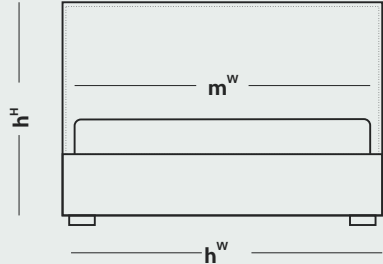
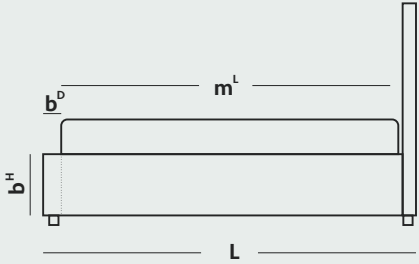
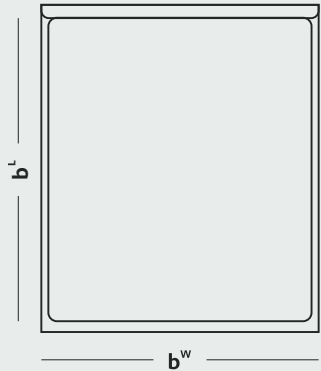



# BELLATRIX

	L	b <sup>L</sup>	b <sup>W</sup>	b <sup>H</sup>	b <sup>D</sup>	h <sup>W</sup>	h <sup>H</sup>	m <sup>L</sup>	m <sup>W</sup> (cm)
<b>Design Bed</b>	213	205	190	35	5	190	120	200	180
	213	205	170	35	5	170	120	200	160

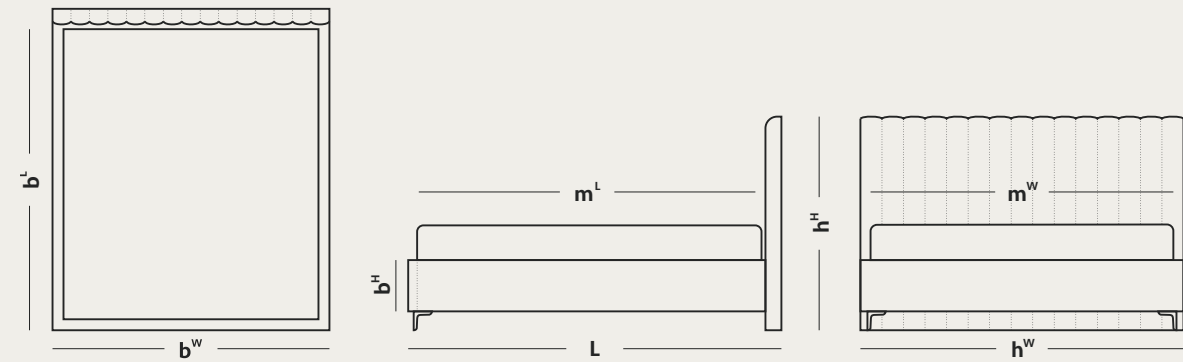



# ATLAS

	L	b <sup>L</sup>	b <sup>W</sup>	b <sup>H</sup>	h <sup>W</sup>	h <sup>H</sup>	m <sup>L</sup>	m <sup>W</sup> (cm)
<b>Boxspring 22</b>	225	200	180	22	180	100	200	180
	225	200	160	22	160	100	200	160

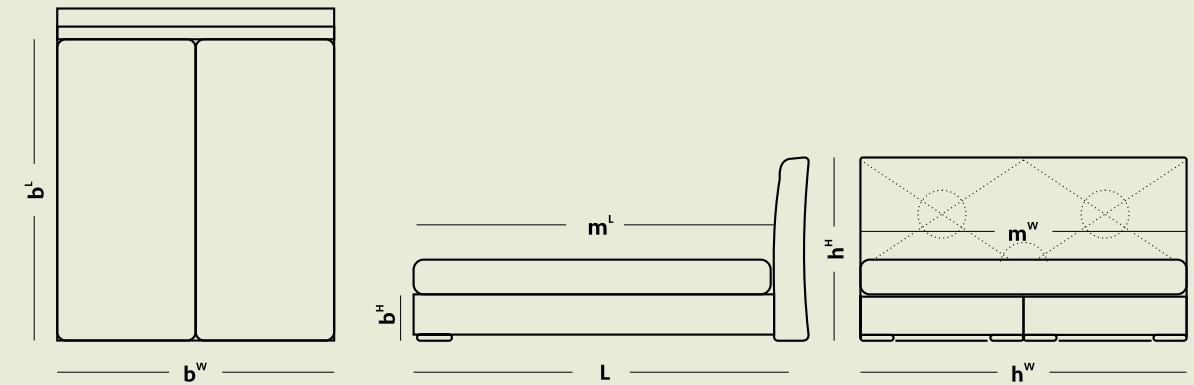



# PRESTIGE

	<b>L</b>	<b>b<sup>L</sup></b>	<b>b<sup>W</sup></b>	<b>b<sup>H</sup></b>	<b>b<sup>D</sup></b>	<b>h<sup>W</sup></b>	<b>h<sup>H</sup></b>	<b>m<sup>L</sup></b>	<b>m<sup>W</sup></b> (cm)
<b>Design Bed</b>	218	205	190	15	5	190	140	200	180
	218	205	170	15	5	170	140	200	160

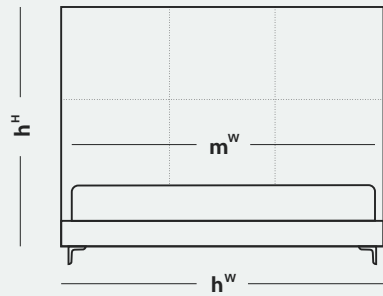
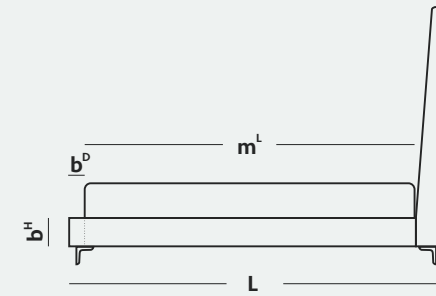
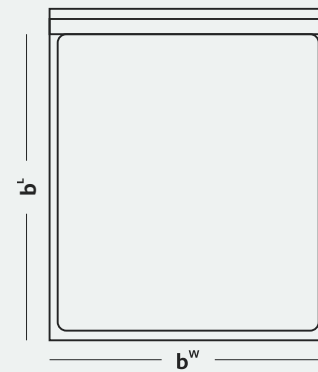

# SIENA

	L	b <sup>L</sup>	b <sup>W</sup>	b <sup>H</sup>	b <sup>D</sup>	h <sup>W</sup>	h <sup>H</sup>	m <sup>L</sup>	m <sup>W</sup> (cm)
Design Bed	219	205	190	30	5	190	105	200	180
	219	205	170	30	5	170	105	200	160

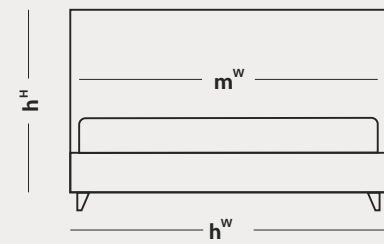
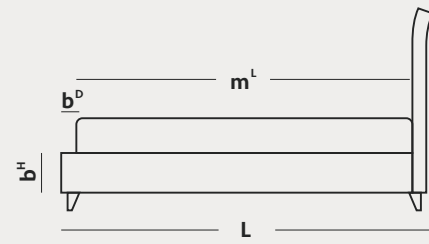
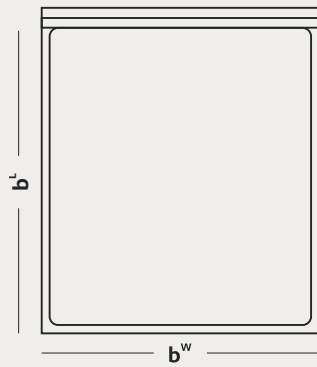

# CORONA

	L	b <sup>L</sup>	b <sup>W</sup>	b <sup>H</sup>	h <sup>W</sup>	h <sup>H</sup>	m <sup>L</sup>	m <sup>W</sup> (cm)
<b>MAXI</b>	208	200	180	32	180	120	200	180
	208	200	160	32	160	120	200	160

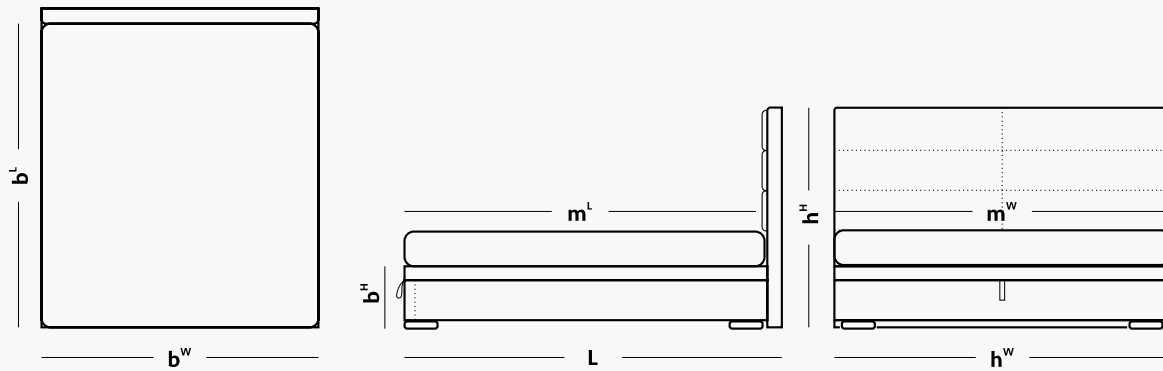



# ALESIA

	L	b <sup>L</sup>	b <sup>W</sup>	b <sup>H</sup>	b <sup>D</sup>	h <sup>W</sup>	h <sup>H</sup>	m <sup>L</sup>	m <sup>W</sup> (cm)
Design Bed	217	205	190	30	5	190	103	200	180
	217	205	170	30	5	170	103	200	160

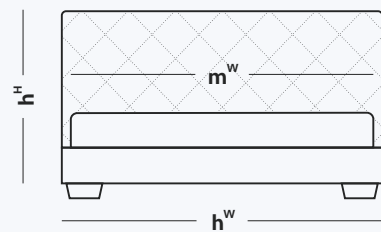
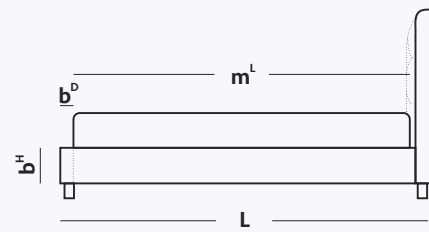
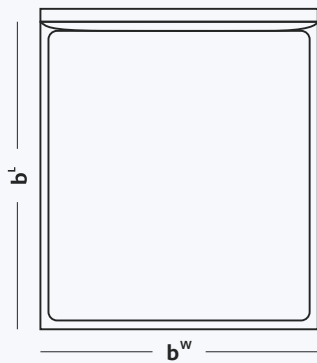

# MIRACH

	<b>L</b>	<b>b<sup>L</sup></b>	<b>b<sup>W</sup></b>	<b>b<sup>H</sup></b>	<b>h<sup>W</sup></b>	<b>h<sup>H</sup></b>	<b>m<sup>L</sup></b>	<b>m<sup>W</sup></b> (cm)
<b>Boxspring 22</b>	208	200	180	22	190	130	200	180
	208	200	160	22	170	130	200	160

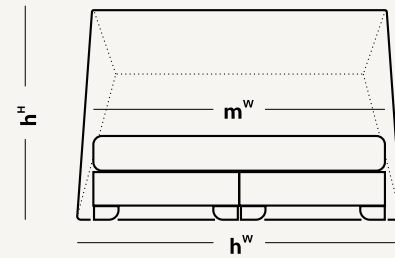
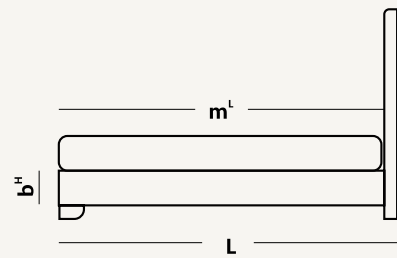
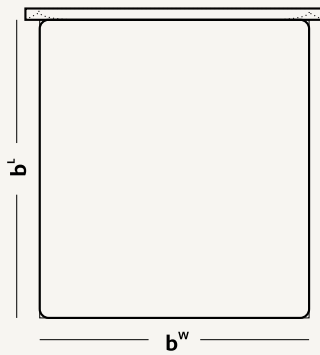



# PARIS

	<b>L</b>	<b>b<sup>L</sup></b>	<b>b<sup>W</sup></b>	<b>b<sup>H</sup></b>	<b>h<sup>W</sup></b>	<b>h<sup>H</sup></b>	<b>m<sup>L</sup></b>	<b>m<sup>W</sup></b> (cm)
<b>Boxspring 32 + Cover</b>	208	200	180	32	180	197	200	180
	208	200	160	32	160	197	200	160

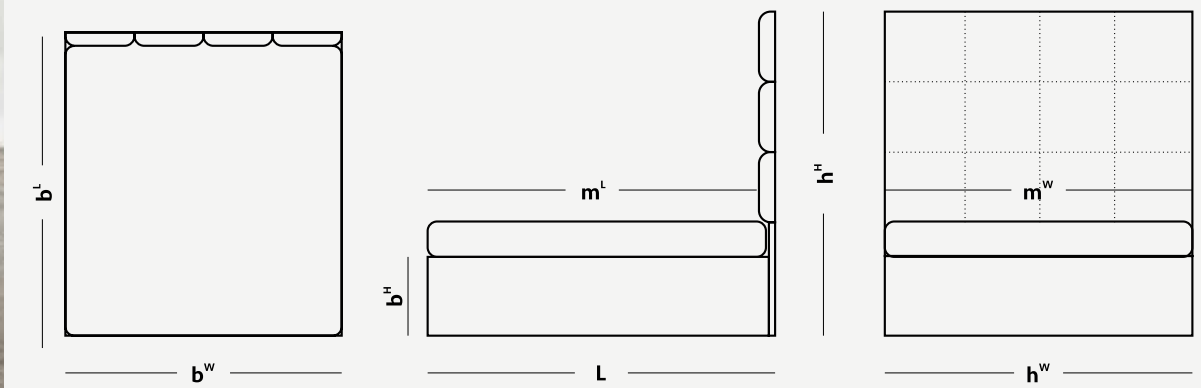



# VIENNA

	L	b <sup>L</sup>	b <sup>W</sup>	b <sup>H</sup>	h <sup>W</sup>	h <sup>H</sup>	m <sup>L</sup>	m <sup>W</sup>	(cm)
<b>Boxspring 32</b>	208	200	180	32	190	170	200	180	
	208	200	160	32	170	170	200	160	

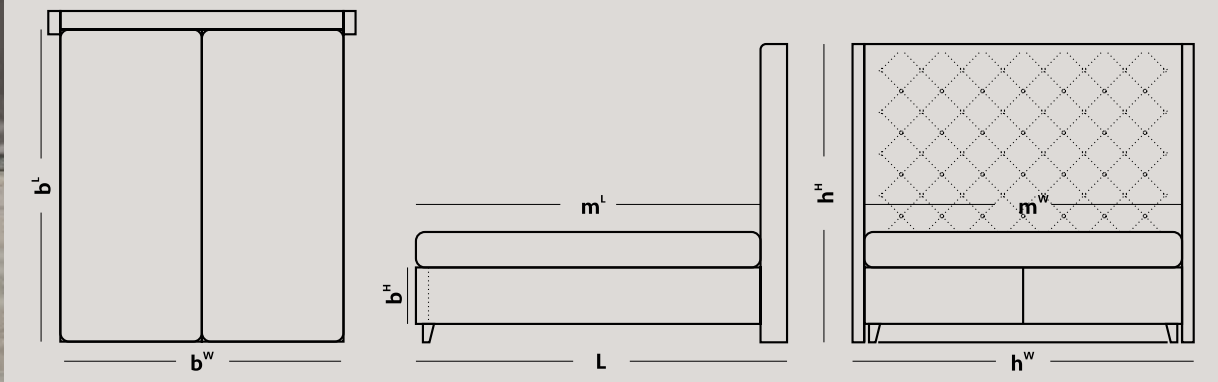



# DE LUXE

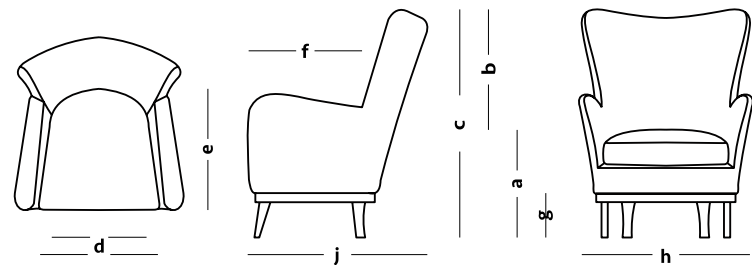

	a	b	c	d	e	f	g	h	j	(cm)
Castel	45	55	100	56/42	54	49	20	79	80	
Line	46	55	101	56/42	54	49	21	79	80	

# BREEZE

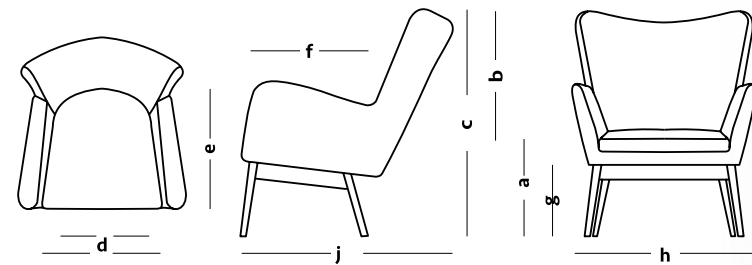

	a	b	c	d	e	f	g	h	j	(cm)
Cut	45	63	94	56/42	56	42	26/31	78	85	
Cross	45	63	102	56/42	56	42	32	78	80	

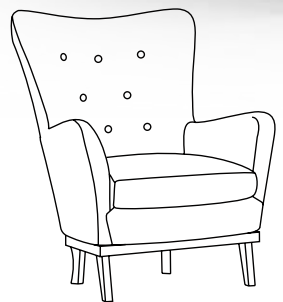

Button

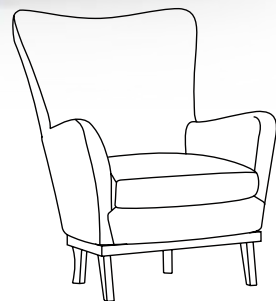

Clean

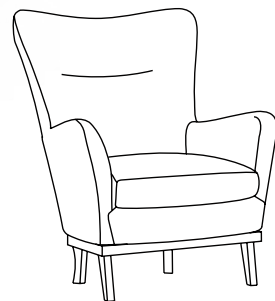

Mirach

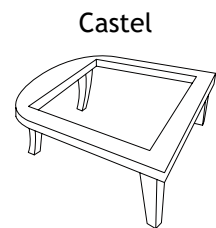

Castel

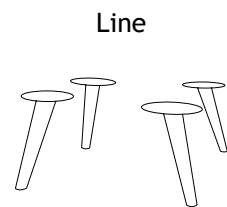

Line

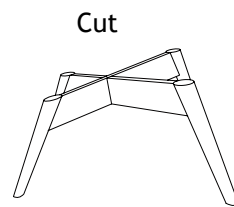

Cut

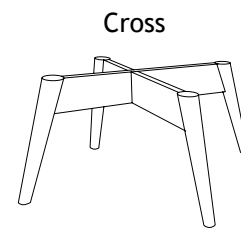

Cross

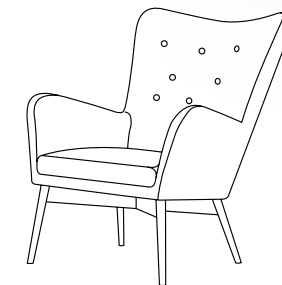

Button

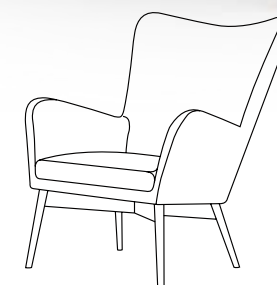

Clean

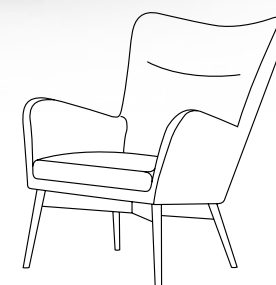

Mirach



# MODERN

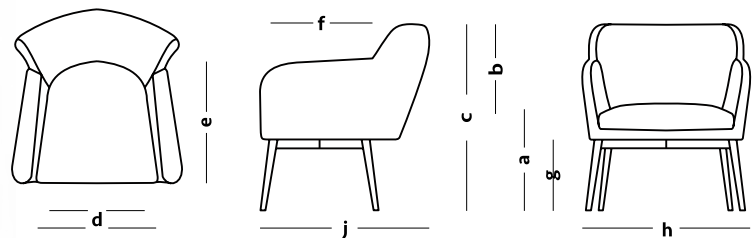

	a	b	c	d	e	f	g	h	j	(cm)
cut	46	33	69	55/44	56	42	26/31	75	79	
cross	45	33	78	55/44	56	42	32	75	75	

45

Cut

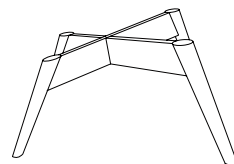

Cross

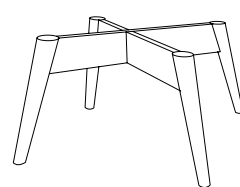

# TABURET

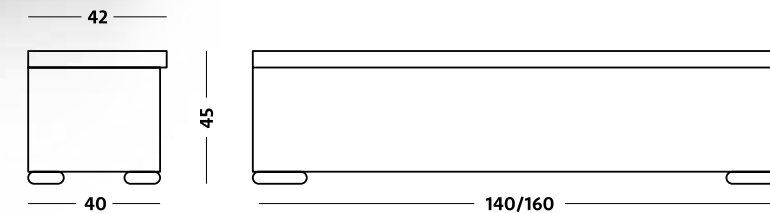

ZMENIŤ ROZMERY NOŽIČIEK

# Wood

Wood 1 (13 cm) (8, 10, 13 cm)



Natur White Wenge

Castello (10 cm) (13 cm)



Cube (10 cm)



Wood 2 (8 cm)



Wenge  
Nut  
Natur

Wood 3 (8 cm)



Wenge  
Nut  
Natur

# Metal

Elegance (13 cm)



Fancy (13 cm)



Polygon (10 cm)



Chrome (11 cm)



Metal (8 cm)



Floor (3 cm)



# Plastic

Standard 2 (10 cm)



Standard 1 (5 cm)





Obrázky sú ilustračné. Obrázky jsou ilustrativní. Images are illustrative.  
Bilder sind illustrativ. Obrazy są ilustracyjne. Las imagenes son ilustrativas  
© materasso s.r.o.



